

STL1166 - STL1166K

TELAIETTO LATERALE SPECIFICO - SPECIFIC SADDLEBAG TUBULAR HOLDER - SUPPORT TUBULAIRE POUR SACOCHES CAVALIÈRES - SPEZIAL SEITENTRAEGER FUER WEICHTASCHEN - PORTA ALFORJAS TUBULAR LATERAL - SUPORTE LATERAL DE ALFORGES

N°	Descrizione/Description	Caratteristiche/Features	Codice/Code	Quantità/quantity
1	Telaio laterale - Side frame - Châssis latéral Soporte lateral - Seitenrahmen - Suporte lateral	-	STL	2(DX-SX)
2	Supporto - Support - Support Halterung - Soporte - Apoio	-	GL6529DXV GL6529SXV	2(DX-SX)
3	Vite - Screw - Vis - Schraube Tornillo - Parafuso	TECF M8x40	840TECF	4
4	Distanziale - Spacer - Entretoise - Distanzstueck Distanciador - Espaçador	Ø20x4 Foro 10,5mm	C20L4F10,5T	4
5	Componenti Originali - Original Parts Parties Originales - Original Bauteile Componentes Originales - Componentes Originais	-	-	-

IT_ Nel caso in cui sulle viti originali sia presente del frenafili, ripristinarlo durante il montaggio dell'accessorio.

EN_ If there is threadlocker on the original screws, use threadlocker when mounting the accessory.

DE_ Falls sich auf den Originalschrauben Schraubensicherungsstoff befand, sollte dieser auch bei der Montage des Zubehörs wieder aufgetragen werden

FR_ Si du frein filet est présent sur les vis d'origine, l'appliquer également lors du montage de l'accessoire

ES_ En caso de que el fijador de roscas se encuentre presente en los tornillos originales, colocarlo nuevamente en el montaje del accesorio

PT_ Se houver trava rosca nos parafusos originais, inserir novamente durante a montagem do acessório

- ATTENZIONE : STRINGERE LE VITI SOLO DOPO AVER ULTIMATO IL CORRETTO POSIZIONAMENTO DEI COMPONENTI

- CAUTION : TIGHTEN THE SCREW ONLY AFTER COMPONENTS HAVE BEEN PLACED IN THEIR CORRECT POSITIONS.

- ATTENTION : SERRER LES VIS QUE LORSQUE LES COMPOSANTS ONT ÉTÉ MISES EN POSITION CORRECTE.

- ACHTUNG : SCHRAUBE ERST DANN ANZUZIEHEN, WENN DIE KOMPONENTEN POSITIONIERT SIND.

- ATENCIÓN : APRETAR LOS TORNILLOS SOLO DESPUES DE HABER ULTIMADO EL CORRECTO POSICIONAMIENTO DE LOS COMPONENTES.

- CUIDADO : APERTAR O PARAFUSO SOMENTE DEPOIS QUE COMPONENTES FORAM COLOCADOS NAS POSIÇÕES CORRETAS.

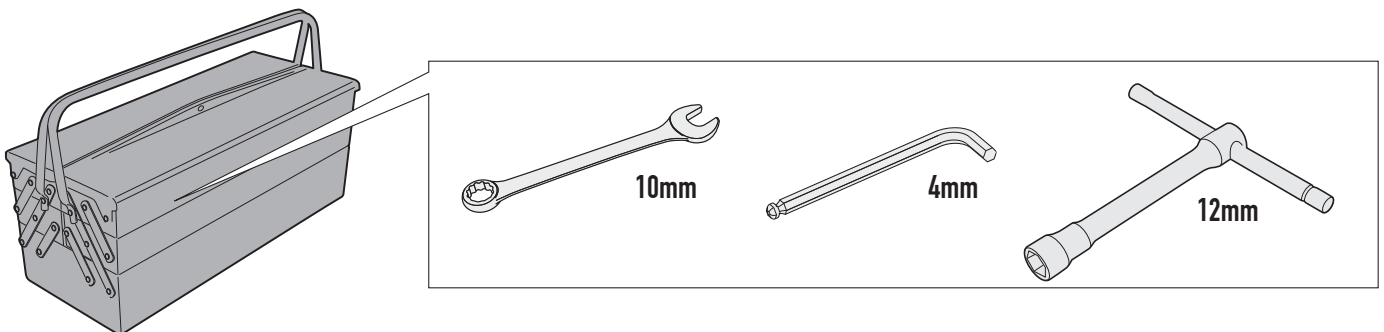
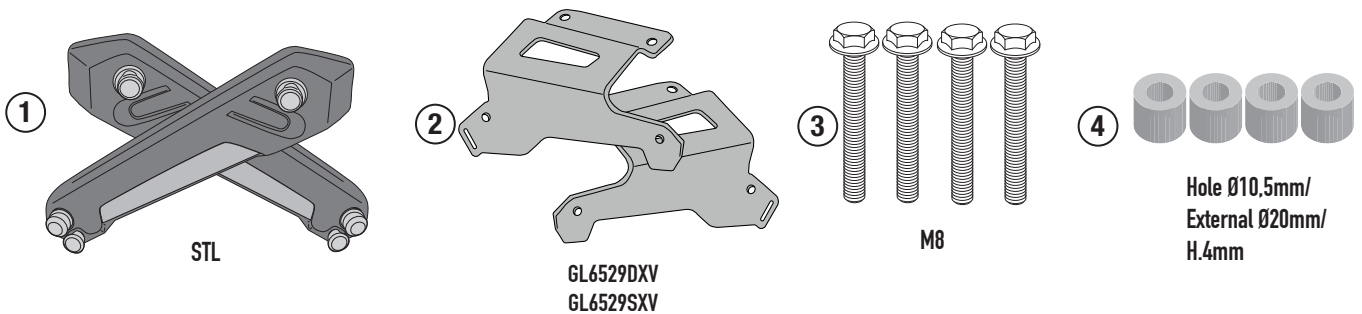

ISTRUZIONI DI MONTAGGIO - MOUNTING INSTRUCTIONS
INSTRUCTIONS DE MONTAGE - BAUANLEITUNG
INSTRUCCIONES DE MONTAJE - INSTRUÇÕES DE MONTAGEM

STL1166 - STL1166K

TELAIETTO LATERALE SPECIFICO - SPECIFIC SADDLEBAG TUBULAR HOLDER - SUPPORT TUBULAIRE POUR SACOCHES CAVALIÈRES - SPEZIAL SEITENTRAEGER FUER WEICHTASCHEN - PORTA ALFORJAS TUBULAR LATERAL - SUPORTE LATERAL DE ALFORGES

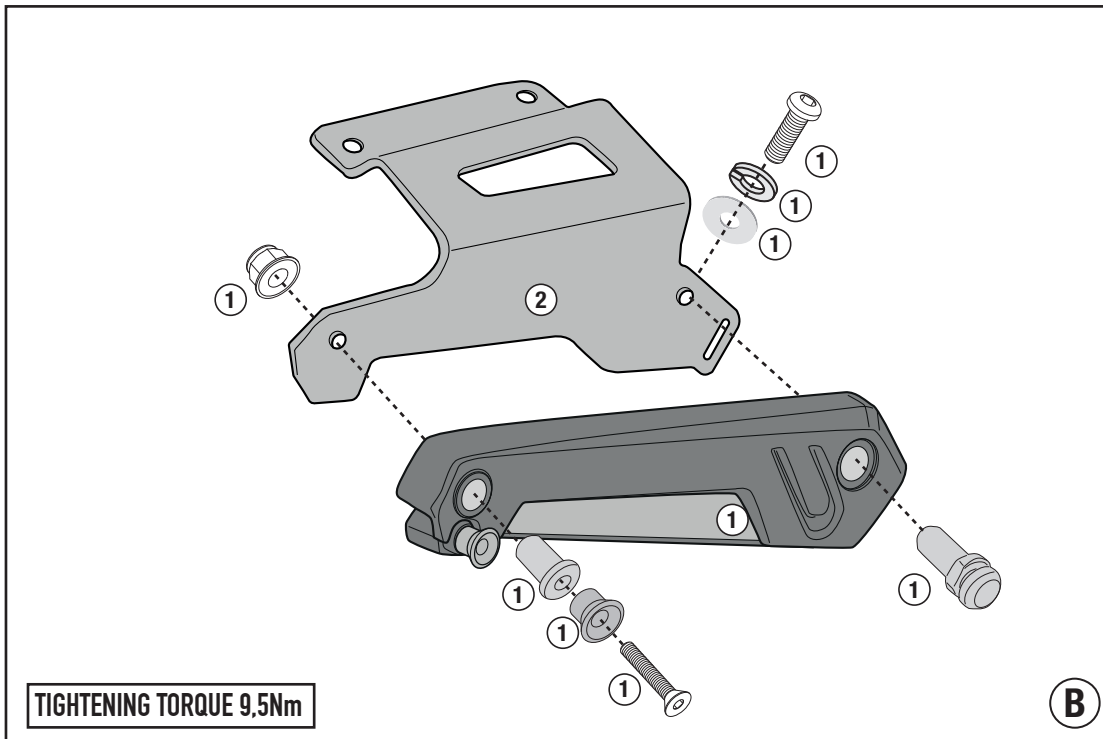
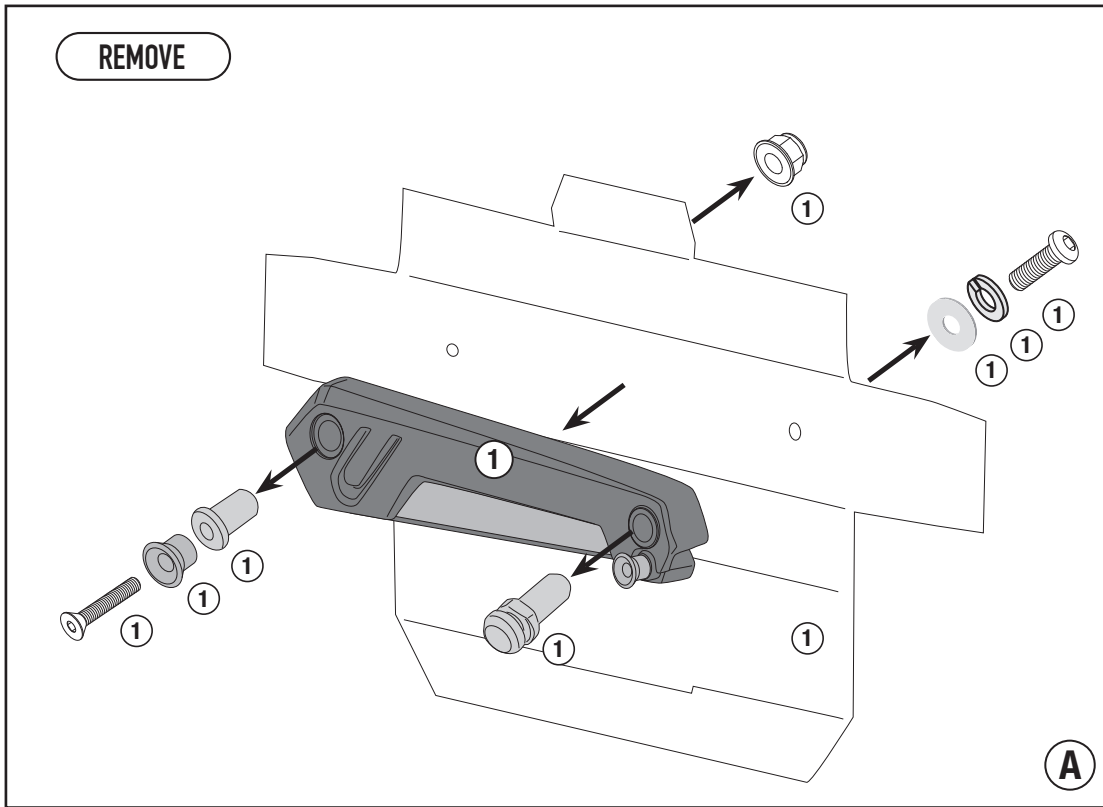

STL1166 - STL1166K

TELAIETTO LATERALE SPECIFICO - SPECIFIC SADDLEBAG TUBULAR HOLDER - SUPPORT TUBULAIRE POUR SACOCHES CAVALIÈRES - SPEZIAL SEITENTRAEGER FUER
WEICHTASCHEN - PORTA ALFORJAS TUBULAR LATERAL - SUPORTE LATERAL DE ALFORGES

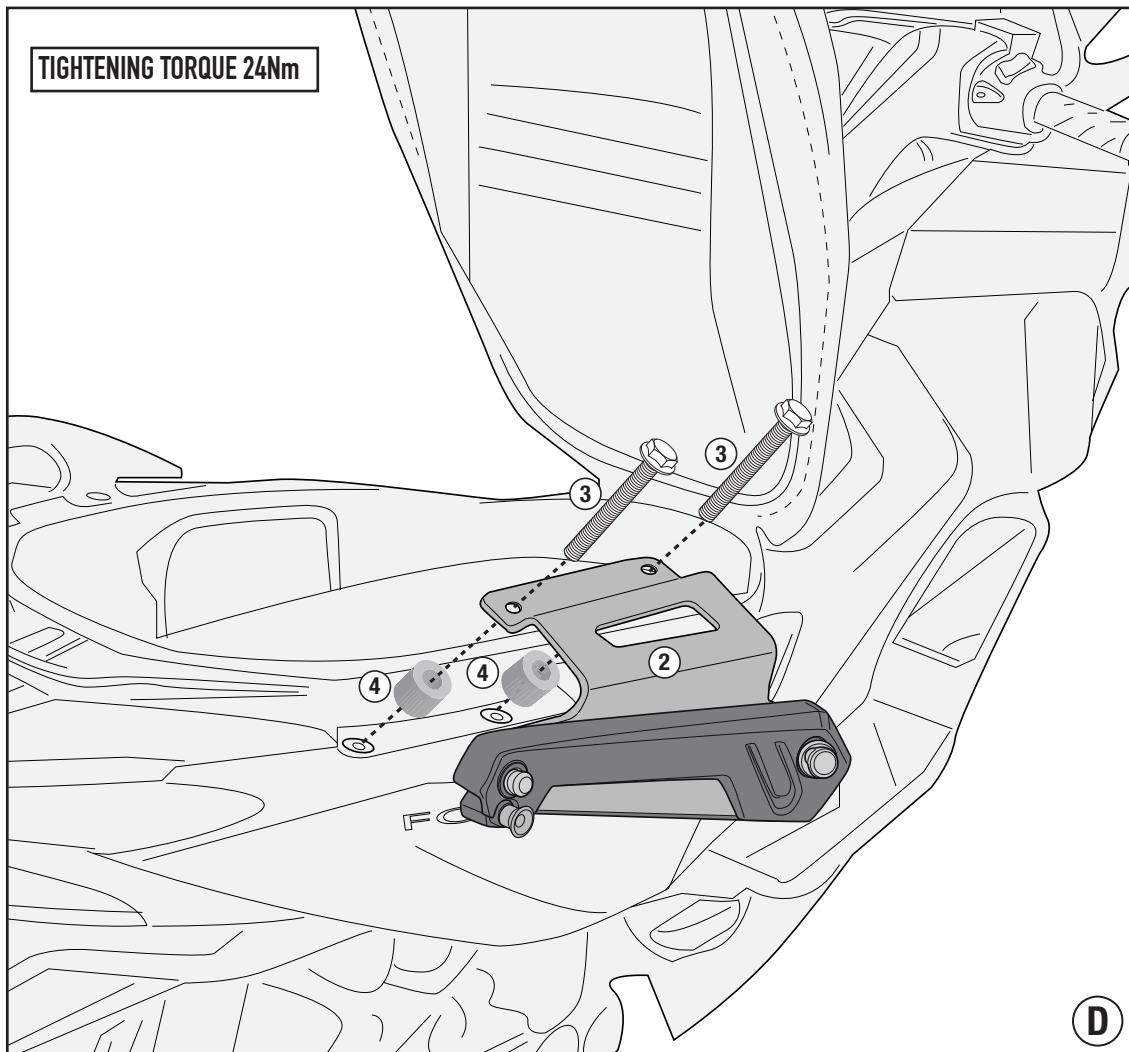
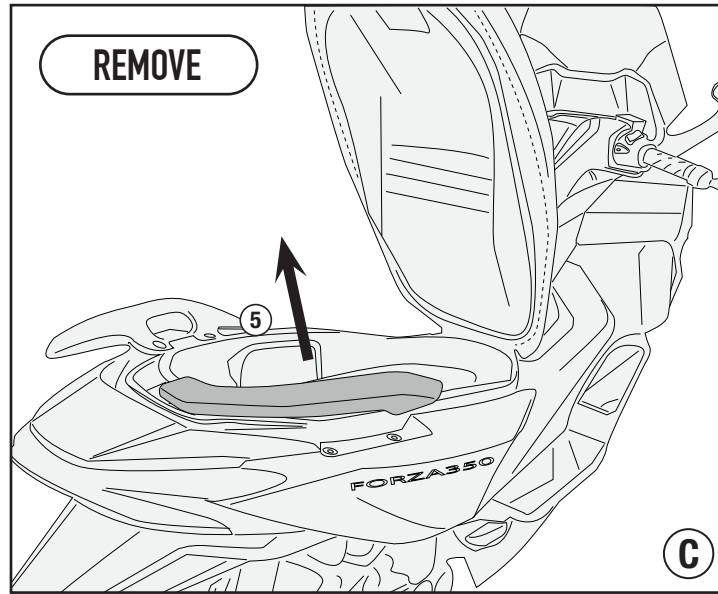

STL1166 - STL1166K

TELAIETTO LATERALE SPECIFICO - SPECIFIC SADDLEBAG TUBULAR HOLDER - SUPPORT TUBULAIRE POUR SACOCHES CAVALIÈRES - SPEZIAL SEITENTRAEGER FUER WEICHTASCHEN - PORTA ALFORJAS TUBULAR LATERAL - SUORTE LATERAL DE ALFORGES

PER APRIRE / TO OPEN / ZUM ÖFFNEN / POUR OUVRIR / PARA ABRIR / PARA ABRIR

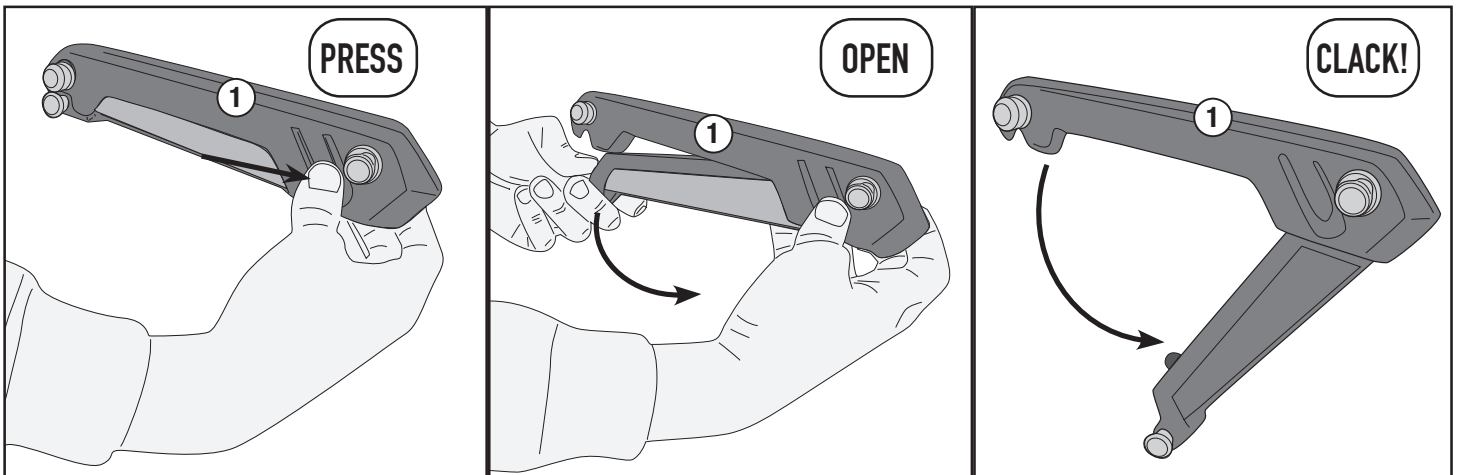

PER CHIUDERE / TO CLOSE / ZUM SCHLIESSEN / POUR FERMER / PARA CERRAR / PARA ENCERRAR

