

E235S

SCHIENALINO - BACKREST - DOSSERET BEIFAHNER-RÜCKENLEHNE - RESPALDO - ENCOSTO

N°	Descrizione	Caratteristiche	Codice	Quantità
1	Schienalino - Backrest Dossieret - Beifahrer-Rückenlehne Respaldo - Encosto	-	E235S	1
2	Vite - Screw Vis - Schraube Tornillo - Parafuso)	TL M6x20	620TL	4
3	Rondella In Gomma - Rubber Washer Rondelle En Caoutchouc - Gummi Scheibe Arandela De Goma - Arruela De Borracha	Foro Ø6 / Esterno Ø18 / Sp.3mm	Z267	4
4	Rondella In Gomma - Rubber Washer Rondelle En Caoutchouc - Gummi Scheibe Arandela De Goma - Arruela De Borracha	Foro Ø6 / Esterno Ø16 / Sp.2mm	ORONG	4

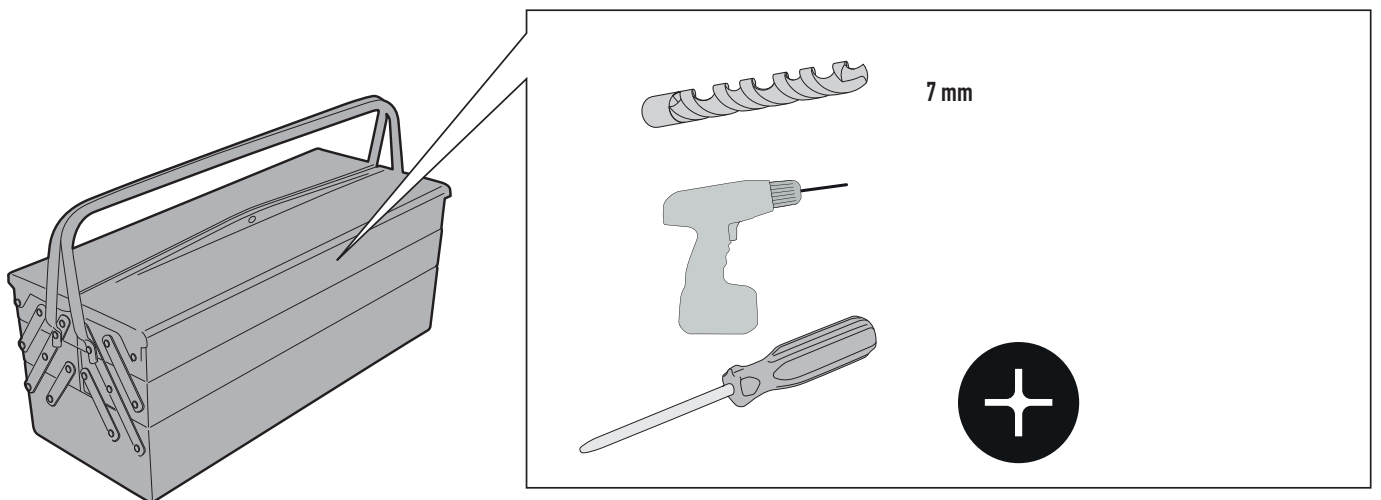
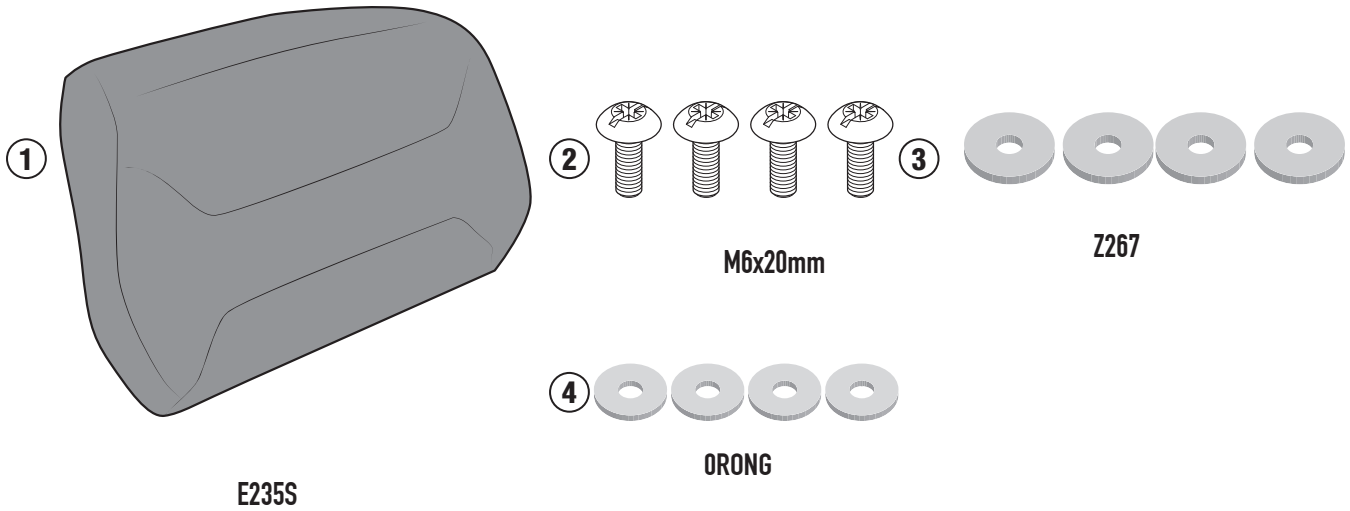

E235S

SCHIENALINO - BACKREST - DOSSERET BEIFAHRENER-RÜCKENLEHNE - RESPALDO - ENCOSTO

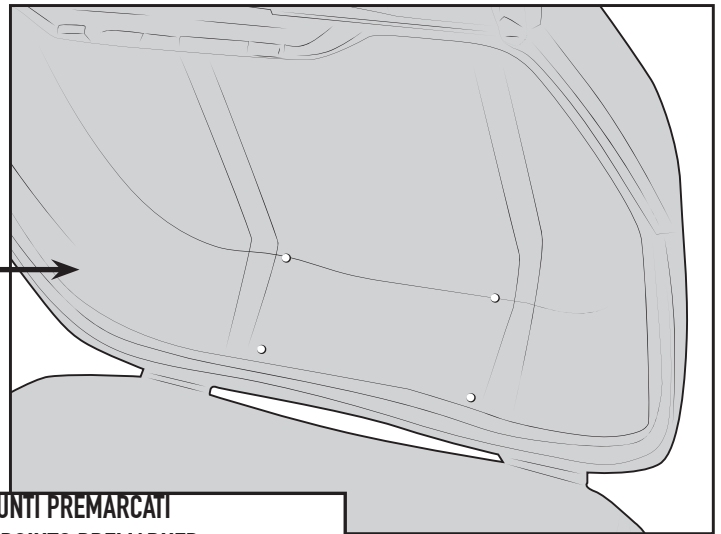
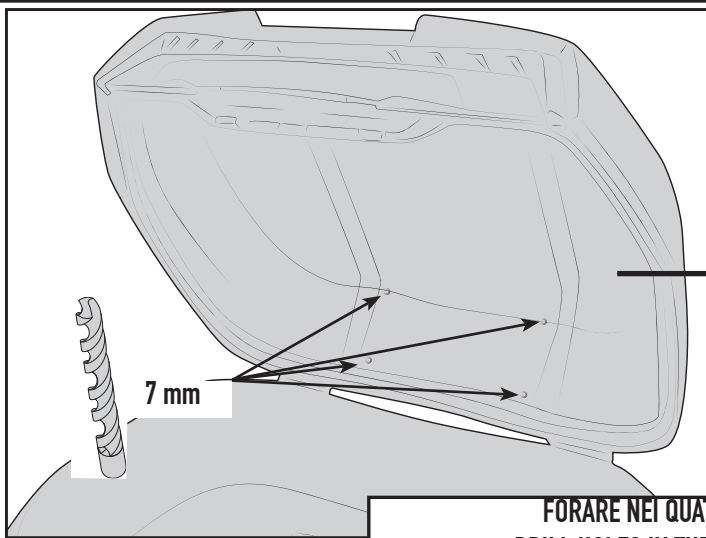

FORARE NEI QUATTRO PUNTI PREMARCATI
DRILL HOLES IN THE FOUR POINTS PREMARKED
PERCEZ DES TROUS DANS LES QUATRE POINTS PRÉMARQUÉES
LÖCHER IN DIE VIER PUNKTE VORMARKIERTE
PERFORAR LOS CUATRO PUNTOS PREVIAMENTE MARCADA
PERFURAR OS QUATRO PONTOS PREVIAMENTE MARCADOS

